



Topic:

MILA GARANT BRAKE I WILL BE DISCONTINUED!

AUG. 2011

MILA GARANT BRAKE I

MILA GARANT brake I will be discontinued when stock is sold out. Presumably our stock and last pending order will last until end of October 2011.

However, we have already run out of fixing bracket 038372 and recommend fixing bracket 390362 as its replacement. As the supplier no longer exists we are unable to provide any more 038372.

The products in question appear from page 2 and 3.

MILA GARANT BRAKE II

MILA GARANT brake I is replaced by the new and improved **MILA GARANT brake II**. This brake covers the same size ranges, but is based

on a different technology (rotating rod instead of pulling rod).

To be used together with **BRAKE CONNECTOR II**, for 12 or 15 mm tongue respectively, and **FIXING BRACKET II** (these do *not* fit brake I). Besides the brake connectors shown on page 5 we will also soon have a brake connector with mushroom cam for 12 mm air gap (for FAVORIT and AF toothing). Expected in stock at the end of September. (Catalogue page to follow shortly).

Furthermore for general information, we enclose on page 7 the maintenance instruction for brake II. Mounting instruction can be found in our GARANT catalogue which can either be downloaded from our website or ordered on print from our sales department.

SIEGENIA-AUBI BRAKE

For usage together with corners from the Tilt/ Turn programme the Siegenia-Aubi brake is available. In combination with Siegenia-Aubi fixing brackets (for various profile systems) this brake can be used as alternative to brake II. Catalogue pages for FAVORIT and AF-toothing are shown on pages 8 - 10.

Please do not hesitate to call us if you require further information or help to determine the alternative best suited for your hardware solution. (Phone: +45 49 13 99 00, info@mila.dk)

GREBSBETJENT FRIKTIONSREMSE I

16 mm fladstolpe, sølv finish passende til standard euronot.

For kobling med kolvepaskviller via hjørne / bremseoverføring.



Handle Operated Brake I

16 mm flat faceplate, silver finish, fitting standard Euro groove.

For coupling with tongue espags via corner / brake connector.

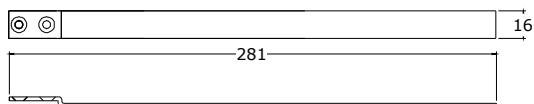

DÆKSKINNE / COVER PLATE

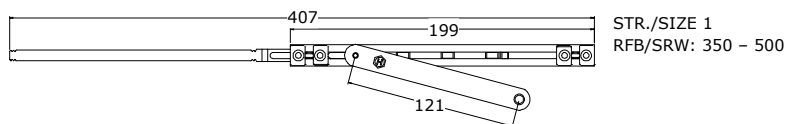

STR./SIZE 1
RFB/SRW: 350 - 500

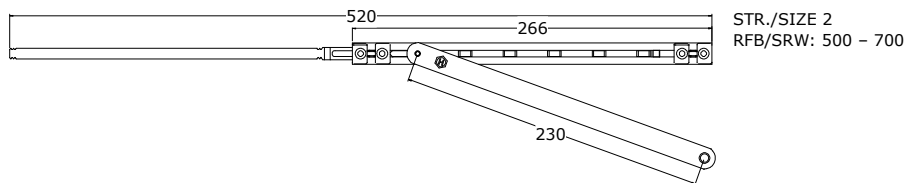

STR./SIZE 2
RFB/SRW: 500 - 700

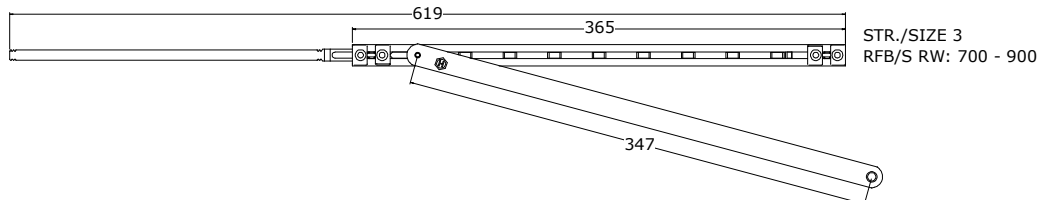

STR./SIZE 3
RFB/S RW: 700 - 900

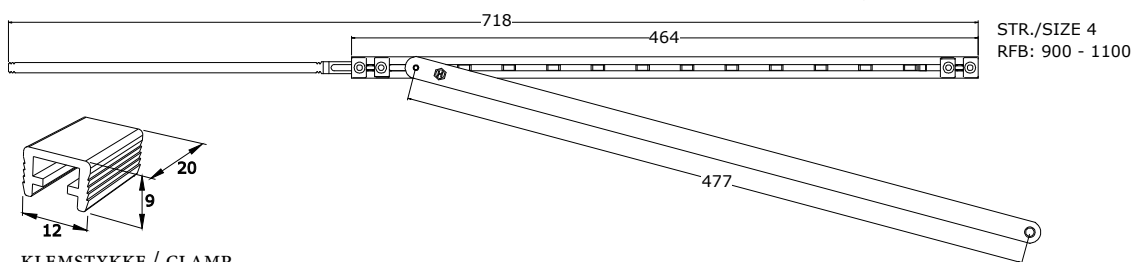

STR./SIZE 4
RFB: 900 - 1100

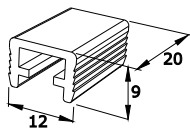

KLEMSTYKKE / CLAMP

ALTERNATIV TIL FASTHOLDELSE AF BREMSE
ALTERNATIVE TO BRAKE FIXATION

ARTIKELNR.	
Størrelse / Size	Nr.
1	038351
2	038352
3	038353
4	038354
Dækskinne / Cover Plate	038355
Klemstykke / Clamp	037006

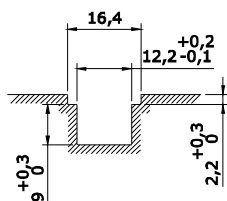

STANDARD EURONOT
STANDARD EURO GROOVE

KARMFÆSTER I

Fixing Bracket I

Karmfæste til 7/12 eller 9/16 not, vendbart.
Anvendes sammen med friktionsbremse I.

*Fixation for 7/12 or 9/16 groove, reversible.
Is used with brake I.*

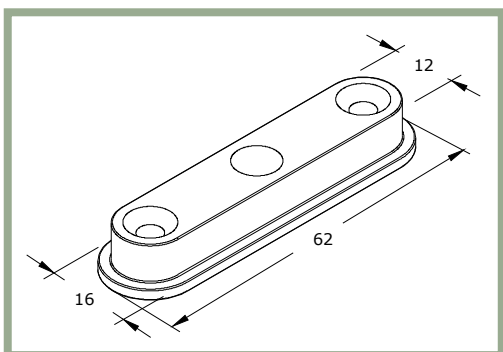

Karmfæste til iskruning.
Iskrues med Torx®30.
Forbores med Ø 15 mm.

*Fixing bracket.
To be fastened with Torx®30.
Pre-drill with Ø 15 mm drill.*

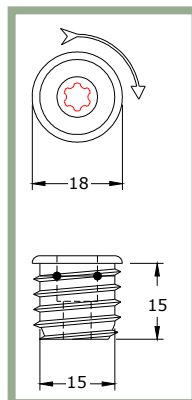

Plant karmfæste, universalt.

Fixing bracket for flush mount, universal.

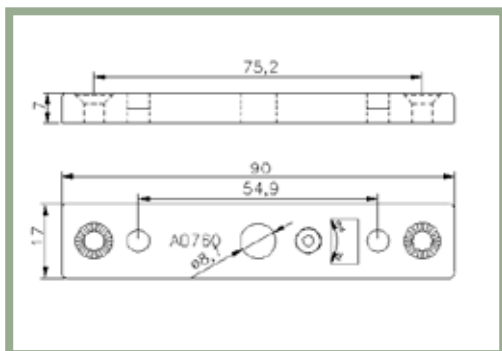

ARTIKELNR.	
Karmfæste i not 7/12 og 9/16 Fix. bracket in groove 7/12 and 9/16	038372
Karmfæste til iskruning Screw-in fixing bracket	038374
Karmfæste, plant Fixing bracket, flush	390362

GREBSBETJENT FRIKTIONSREMSE II.

Sølv finish. Passende til standard euronot.

For kobling med kolvepaskviller via bremseoverføring II (se side 4-003).

Enkel montage med karmfæste II (se side 4-011)

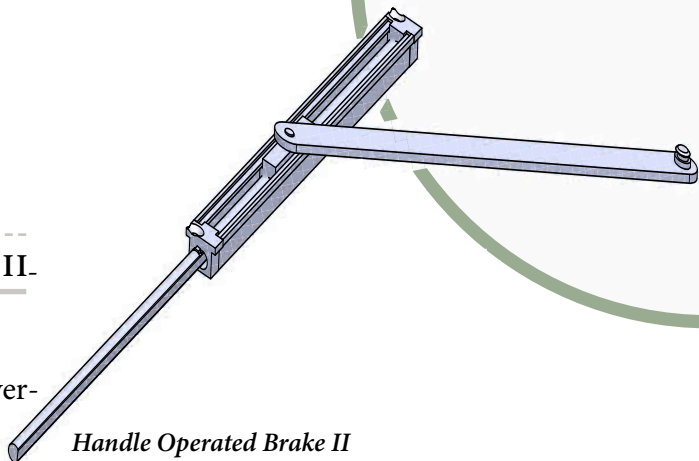

Handle Operated Brake II

Silver finish, fitting standard Euro groove.

For coupling with tongue espags via brake connector (ref. page 4-003).

Easy fitting by means of fixing bracket II (ref. page 4-011).

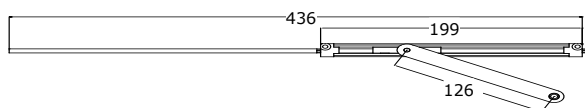

STR./SIZE 1
RFB/SRW: 285 - 500

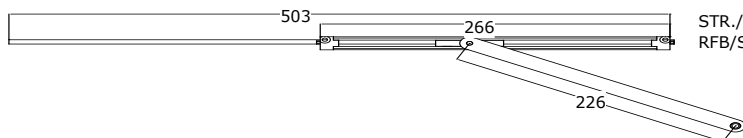

STR./SIZE 2
RFB/SRW: 451 - 700

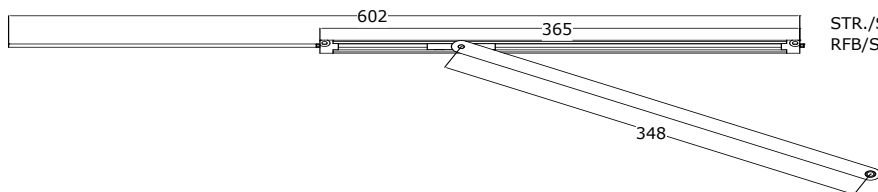

STR./SIZE 3
RFB/SRW: 651 - 900

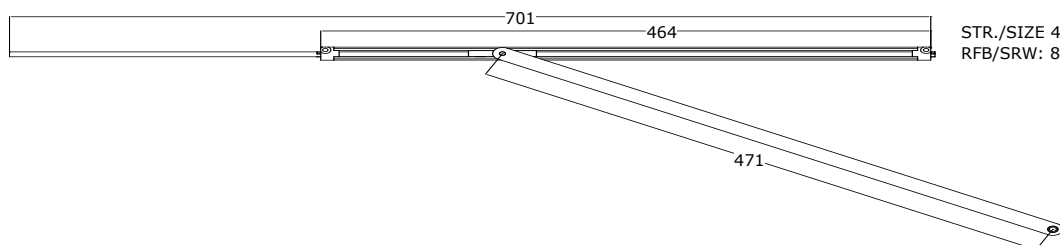

STR./SIZE 4
RFB/SRW: 851 - 1100

ARTIKELNR.	
Størrelse / Size	Nr.
1	038280
2	038281
3	038282
4	038283

BREMSEOVERFØRING II

16 mm fladstolpe, sølv finish.

For kobling med kolvepaskviller.

Brake Connectors II

16 mm flat faceplate, silver finish.

For coupling with tongue espags.

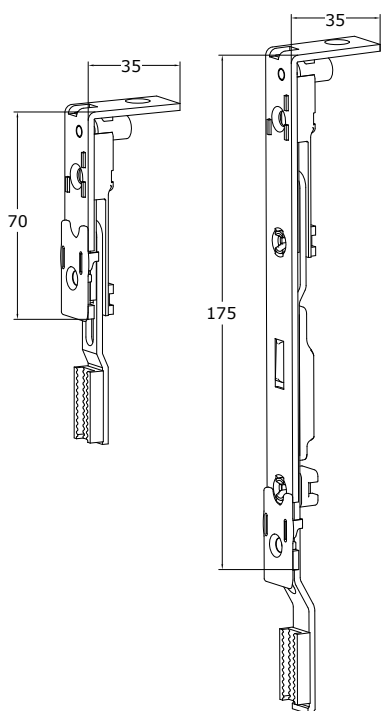
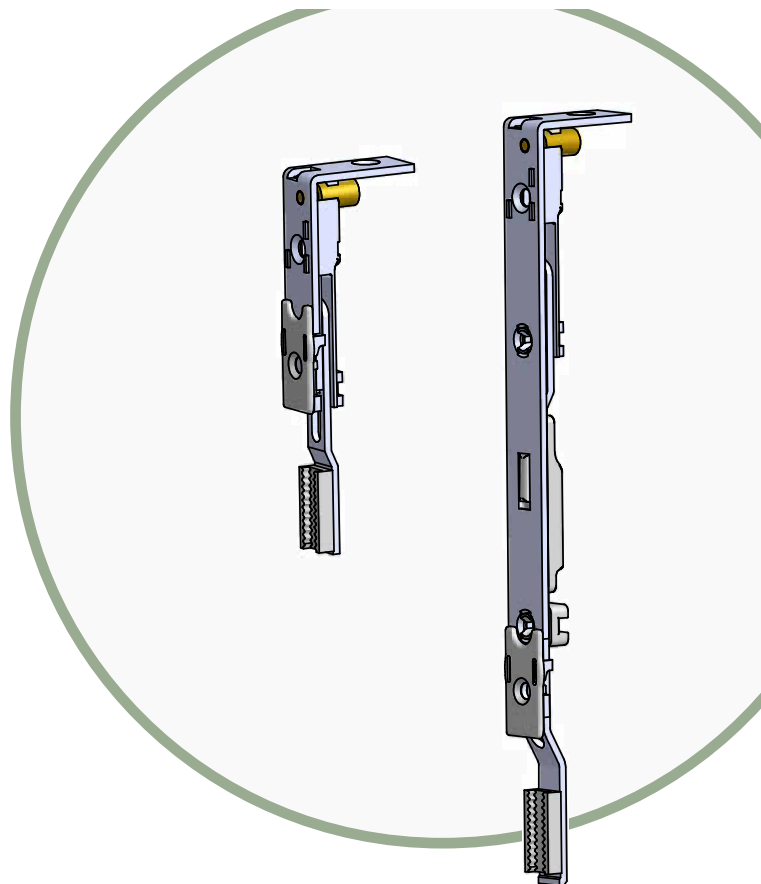

ARTIKELNR.		
Størrelse / Size	12 mm kolve	15 mm kolve
70 mm u. kolve	038272	038273
175 mm m. kolve	038275	038276

KARMFÆSTER II

Fixing Bracket II

Karmfæste til hhv. 9 x 16, 5 x 16 og 7 x 12 mm not. Anvendes sammen med friktionsbremse II

Fixing bracket on for 9 x 16, 15 x 16 and 7 x 12 mm groove.
Is used with brake II.

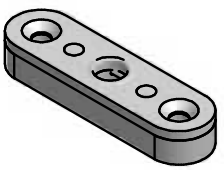
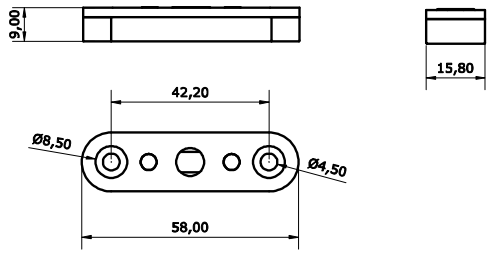
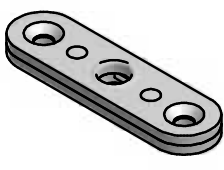
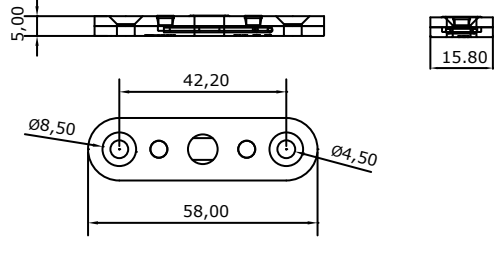
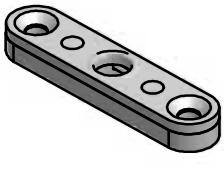
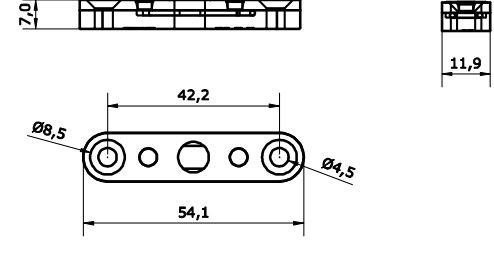
<p>Karmfæste 9 x 16</p> 	
<p>Karmfæste 5 x 16</p> 	
<p>Karmfæste 7 x 12</p> 	

ARTIKELNR.	
9 x 16 mm not	038290
5 x 16 mm not	038291
7 x 12 mm not	038292

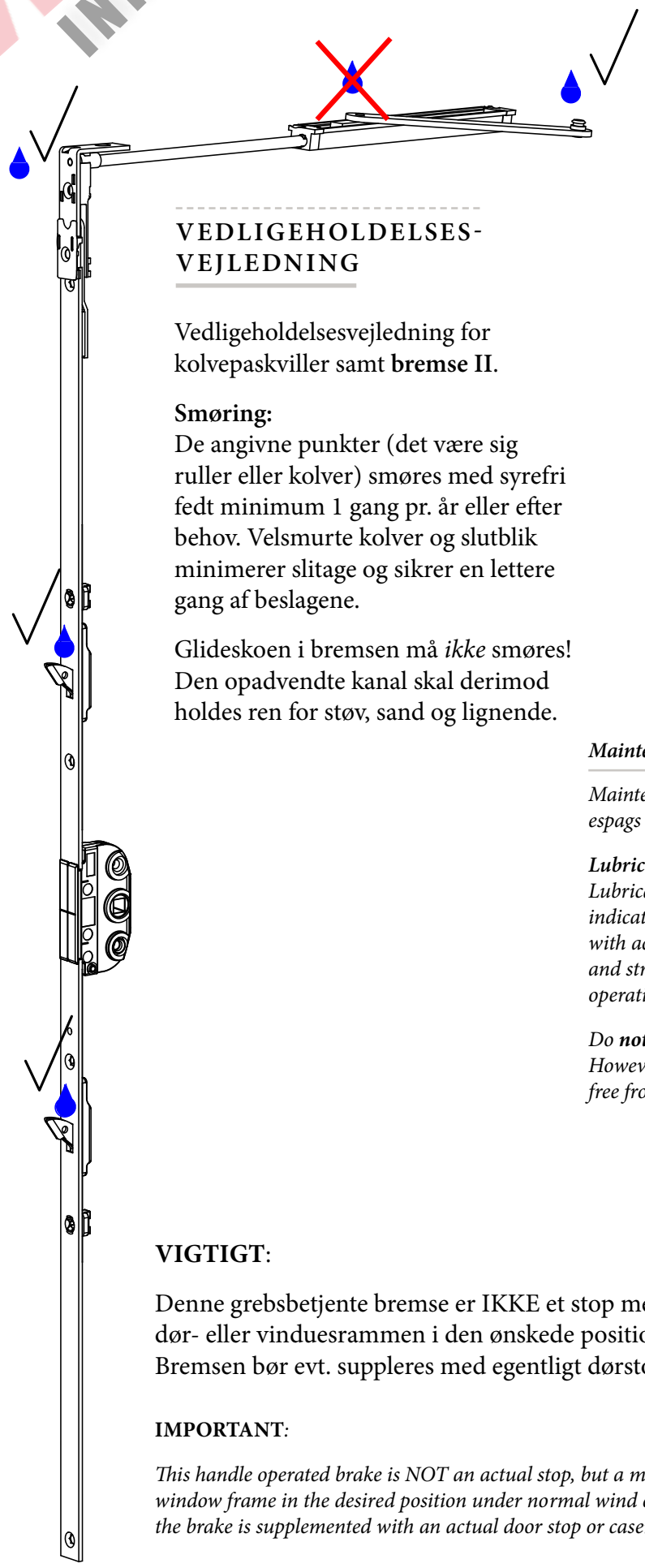

VEDLIGEHOLDELSSES- VEJLEDNING

Vedligeholdelsesvejledning for
kolvepaskviller samt **bremse II**.

Smøring:

De angivne punkter (det være sig
ruller eller kolver) smøres med syrefri
fedt minimum 1 gang pr. år eller efter
behov. Velsmurte kolver og slutblik
minimerer slitage og sikrer en lettere
gang af beslagene.

Glideskoen i bremsen må *ikke* smøres!
Den opadvendte kanal skal derimod
holdes ren for støv, sand og lignende.

Maintenance Instruction

*Maintenance instruction for cam and tongue
espags and **brakes II**.*

Lubrication:

*Lubricate all cams/tongues and strikers as
indicated on the drawing at least once a year
with acid-free grease. Well lubricated tongues
and strikers minimise wear and tear, and ease
operation.*

*Do **not** lubricate the brake shoe!*

*However, the upward facing channel must be kept
free from dust, sand, etc.*

VIGTIGT:

Denne grebsbetjente bremse er IKKE et stop men alene beregnet til at fastholde
dør- eller vinduesrammen i den ønskede position under normale vindforhold.
Bremsen bør evt. suppleres med egentligt dørstop eller stormkrog.

IMPORTANT:

*This handle operated brake is NOT an actual stop, but a means to hold the door or
window frame in the desired position under normal wind conditions. We recommend
the brake is supplemented with an actual door stop or casement hook.*

Baugruppe 2
Schere

Feststellschere schaltbar

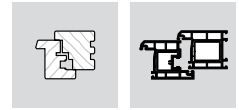

- Ermöglicht das Feststellen des Flügels stufenlos im Öffnungswinkel von 25° - 91°
- Das Feststellen des Flügels im Öffnungswinkel kleiner <25° ist nicht zulässig
- Zum Feststellen des Flügels, den Griff ohne erhöhten Kraftaufwand in Verschlussstellung bringen
- Die Feststellschere ist nicht als Öffnungsbegrenzer einzusetzen, dies könnte zu Schäden am Beschlag führen

Bezeichnung	FFB (mm)	Maße (mm)			🔩	Material-Nummer	
		X	Y	Z			
Feststellschere schaltbar	Gr. 2	680 - 960	132	104	718	4	titan silber FSBR0030-100020
mit							
Zwischenstück	Gr. 230 MV	961 - 1190	132	104	718	4	713259
Bil. Zubehör Feststellsche A...							siehe PDB

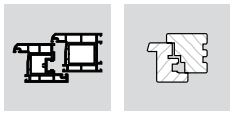

Feststellschere schaltbar

TITAN iP

TSBR

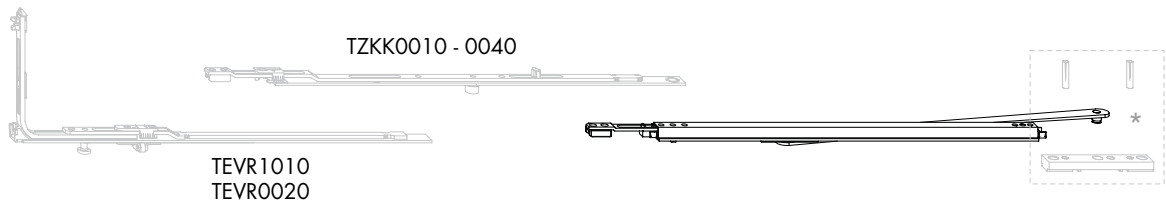

- Ermöglicht das Feststellen des Flügels stufenlos im Öffnungswinkel von 25° - 91°
- Das Feststellen des Flügels im Öffnungswinkel kleiner <25° ist nicht zulässig
- Zum Feststellen des Flügels, den Griff ohne erhöhten Kraftaufwand in Verschlussstellung bringen
- Die Feststellschere ist nicht als Öffnungsbegrenzer einzusetzen, dies könnte zu Schäden am Beschlag führen
- * Btl. Zubehör Bremschere siehe PDB, ZMBR

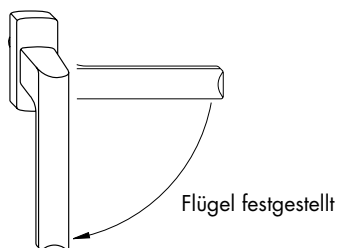
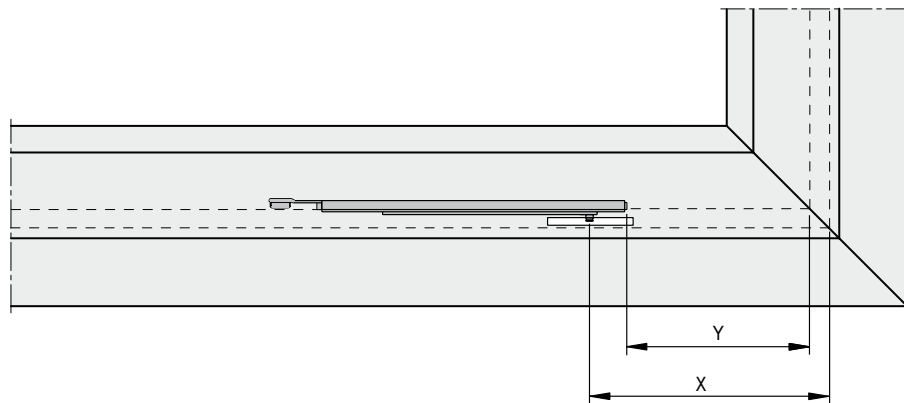

Anwendungsdiagramme in Register 4 sind unbedingt zu beachten!



GS



Materialnummer	Materialkurztext	FFB (mm)	Maße (mm)		Schraubenschlüssel
			X	Y	
TSBR0030- _____	Feststellbremse schaltbar	645 - 1245	132	104	4

TITAN iP
TSBR

Feststellschere schaltbar

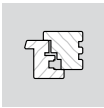
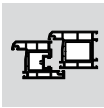

Materialnummer	Materialkurztext	Materialnummer	Materialkurztext	FFB (mm)
TSBR0030- _ _ _ _ _	Feststellbremse schaltbar Gr.2			645 - 845
TSBR0030- _ _ _ _ _	Feststellbremse schaltbar Gr.2	TZKK0010- _ _ _ _ _	Zwischenstück KK Gr.1 1R	846 - 1045
TSBR0030- _ _ _ _ _	Feststellbremse schaltbar Gr.2	TZKK0020- _ _ _ _ _	Zwischenstück KK Gr.2 1R	1046 - 1245